

SanAce PWM Controller Instruction Manual

9PC8666X Series

M0011493C

Thank you for purchasing the San Ace *PWM Controller*.

Please read this instruction manual thoroughly before using the product to fully understand its functions. After thoroughly reading this manual, keep it handy for reference.



CAUTION

- To ensure that the product is used safely, be sure to read and fully understand the Safety Precautions and only use the product as directed.
- Read the Safety Precautions carefully before installing, connecting, operating, maintaining, or inspecting the product.
- The product has been designed and manufactured for use in general industrial machinery, and may not be used as a standalone product.
- The product of our company (hereafter referred to as "the product") falls into the category of the products specified in the Attached List 1, Item 16 (Class 85, Item 43) of the Export Trade Control Ordinance. To export the product as an individual part or to export a device into which the product is assembled, the "Information Requirements" and "Objective Requirements" that the Ministry of Economy, Trade and Industry established based on the "Catchall Controls" must be studied for applicability. Based on information on applicability and specified requirements, appropriate export procedures must be taken.
- When disposing of the product, treat it as industrial waste. For instructions on proper disposal methods, please contact local government authorities.
- When using the product in an environment with vibration, such as in a car or a ship, use it at your own discretion only after deploying sufficient safety measures and making prior evaluations. Fully understand the Safety Precautions described in this instruction manual before using the product.

In order to prevent any possible bodily injury or damage to property or equipment, the following precautions for ensuring safety are displayed according to the following two ranks of importance:

DANGER	Handling or using the product improperly and in disregard of the instructions with this mark may result in serious bodily injury or death.
CAUTION	Handling or using the product improperly and in disregard of the instructions with this mark may result in bodily injury or physical damage.

*Note: Items marked 'Caution' may also result in serious bodily injury or death in some circumstances. Always follow the instructions for items marked 'Danger.'

Safety Precautions

DANGER

- If the product is used in medical appliances or other types of equipment that affect people's lives, sufficient safety-related evaluations and preparations must be made in advance, and the product or the type of equipment into which the product is assembled must be used under the full responsibility of the user.
- If the product is used in types of equipment that have a strong social and public impact, sufficient prior evaluations and safety-related evaluations and preparations must be made, and the product or the type of equipment into which the product is assembled must be used under the full responsibility of the user.
- The product is not designed to be used in a car or a ship. When using the product in an environment with vibration, such as in a car or a ship, use it at your own discretion only after deploying sufficient safety measures and making prior evaluations.
- Connect all wires properly and securely. Failure to do so may result in fire, burns, or electrical shock.
- Do not use the product in a location where there is flammable gas. Otherwise, it may result in fire, burns, or bodily injury.
- Do not operate the product when electronic components are exposed. Otherwise, it may result in electrical shock.
- Turn off the power and stop using the product immediately if you notice any sparks, smoke, odd odors, sounds, or anything unusual during operation. Failure to do so may result in fire, bodily injury, or electrical shock.
- Never allow the product to fall, topple over, or otherwise be subjected to excessive shocks when moving it. Otherwise, it may result in product failure.

- The product should be handled only by personnel with sufficient training and knowledge and under the full responsibility of the user.
- Never attempt to disassemble, repair, or alter the product in any way, as doing so may result in fire, burns, or electrical shock.

CAUTION

Handling

- Installation, placement, connections, wiring, or relocation of the product should be performed by knowledgeable or correctly licensed personnel. Never perform such work while the product is on. Failure to do so may result in bodily injury, fire, burns, or electrical shock.
- Never allow yourself to come into contact with the ends of wires or plugs when measuring insulation resistance or dielectric strength voltage. Otherwise, it may result in electrical shock.
- Never attempt to disassemble or alter the product in any way. Doing so may invalidate any warranties concerning the functions or performance of the product, and may also result in fire, burns, bodily injury, or electrical shock.

Instruction

- Take measures to protect the device from potential damage caused by the product stopping during operation.
- Never use the product at voltages, temperatures, or any other settings which exceed those given in the product specifications. Otherwise, it may result in substandard operation, failure, fire, bodily injury, or electrical shock.
- Never remove the product nameplate or install the product so that the identification cannot be seen after installation. Otherwise, it may result in the product being improperly used, and subsequently result in fires.
- Do not turn the power supply ON/OFF on a ground wire. Otherwise, it may result in product failure.
- Do not apply excessive force to the product while it is operating. Otherwise, it may result in product failure.
- If you install and use the product in a car or a ship, we shall not be responsible for any faults caused by the environment of the car or ship in which the product is installed.

Installation

- When fixing the product into place, be sure to take into consideration the product's weight and all other relevant factors. Failure to do so may result in the product or its parts falling, resulting in bodily injury or device failure.
- Never install or remove the product while it is wired.
- When fixing the product with screws, ensure correct tightening torque. If the tightening torque is over the recommended values, the product structure may deform or break.
- Take proper precautions against static electricity when making electrical connections. Failure to do so may result in device or product failure.
- Make electrical connections properly. Failure to do so may result in device failure, product failure, or product malfunction.
- Ensure that wires are fitted with insulation to prevent accidental short-circuiting. Failure to do so may result in device failure, product failure, or product malfunction.

Operating Environment

- Do not use or store the product where it is exposed to flammable or corrosive gas, water or oil splashes, dust or humidity, condensation, radioactive rays or direct sunlight, salty air or saltwater, or where the product may be contaminated by corrosive materials such as sulfurous water, sulfurous volcanic ash, organic solvents, acidic chemicals, alkali chemicals, nuclear fuel materials, or other hazardous substances. If it is used or stored in such places or environments, there is the possibility that a fire may occur, the product may malfunction or its performance may deteriorate.
- Do not use or store the product in locations and environments where it could be constantly exposed to vibrations, strong shocks, magnetic or electromagnetic noise, or in which electromagnetic noise overlaps into power voltage. Otherwise, it may result in product failure.
- Do not use or store the product in environments subject to sudden changes in temperature and humidity. Otherwise, it may result in product failure.

Maintenance

- Only certified personnel with sufficient training and knowledge should perform maintenance and inspections. Otherwise, it may result in fire, burns, bodily injury, or electrical shock.
- Perform maintenance or inspections while the product is off. Otherwise, it may result in fire, burns, bodily injury, or electrical shock.
- Never use gasoline, paint thinner, benzene, or any other organic solvents to clean the product. Otherwise, it may result in product deformation or substandard operation.

1. Outline

- (1) The San Ace *PWM Controller* is a PWM signal generator that can control the speed of PWM control fans.
- (2) It can use the same or separated DC power supply (12/24/48) as the connected DC fan(s). When using separated DC power supply, the negative line must be common.
- (3) The controller can perform four types of control functions, enabling you to select the best control function to suit your purpose. Only one function can be used at a time.
- (4) The controller can be connected to up to four fans and can be mounted to a DIN rail or mounted with screws.

2. Part Names

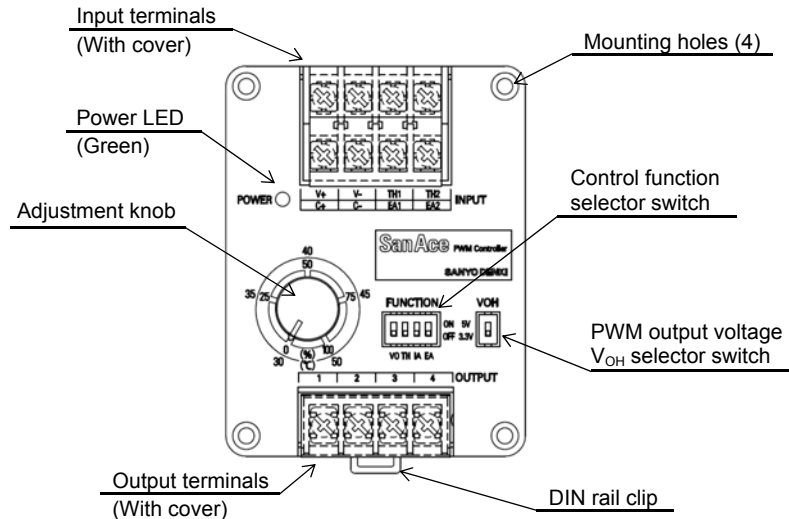

3. Mounting

The controller can be mounted to a 35 mm DIN rail or mounted with screws.

3-1. Mounting the Controller to a DIN Rail

Set the controller so that the DIN rail clip is at the bottom. On the rear side, place the controller's upper hook onto the upper lip of the DIN rail and press on the lower part of the controller until you hear a 'click'.

3-2. Removing the Controller from a DIN Rail

While pulling down the DIN rail clip using a slotted screwdriver, lift the controller up and away from the rail.

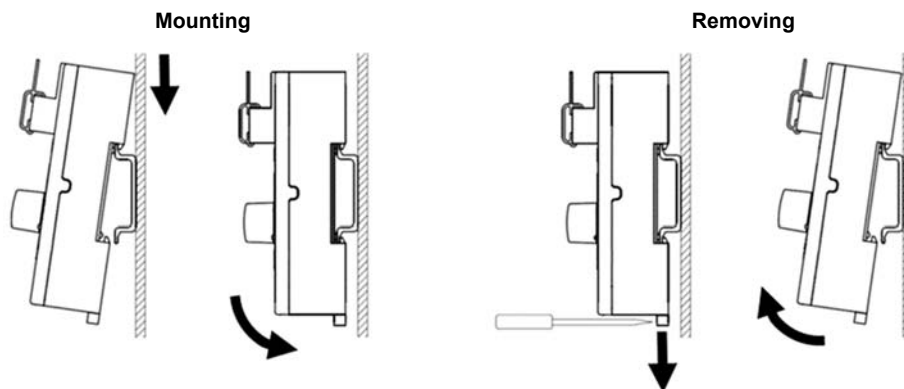

3-3. Mounting with Screws

Insert an M3 screw in each of the four mounting holes and tighten. (Tightening torque: 0.5 N·m max.)

4. I/O Terminals

4-1. Arrangement and Functions

Input Terminals

Terminal	Function
V+	Power supply input
V-	Ground
TH1	Thermistor connection
TH2	Thermistor connection
C+	Control voltage input
C-	Control voltage ground or variable resistor connection
EA1	Variable resistor connection
EA2	Variable resistor connection

Input Terminal Arrangement

V+	V-	TH1	TH2
C+	C-	EA1	EA2

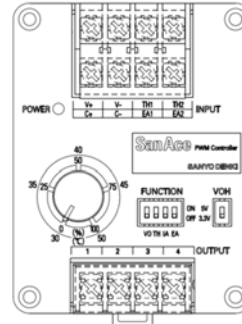

Output Terminals

Terminal	Function
1 to 4	PWM signal output

Output Terminal Arrangement

1	2	3	4
---	---	---	---

4-2. Wiring

- Remove the terminal cover, insert the wire underneath the screw head, and tighten the terminal screw. (M3 terminal screw, tightening torque: 0.5 N·m max.)
- Connect the solderless terminal.
- After confirming the wiring, reattach the terminal cover and turn the power on.
- The PWM signal output may be subject to noise and impedance due to the wiring conditions. Use wires as thick and short as possible.

Recommended Solderless Terminal

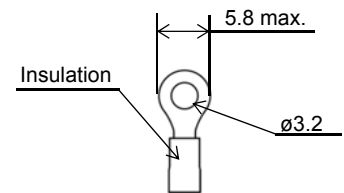

5. Using the PWM Controller

5-1. Selecting V_{OH}

PWM output voltage V_{OH} can be set to 3.3 V or 5 V using the switch. Select the V_{OH} matching the specifications of the connected fan(s).

V_{OH} Selector Switch

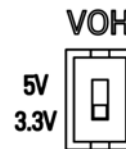

5-2. Selecting the Control Functions

- The controller can perform four types of control functions.
- Make sure only the function being used is ON and that all other functions are OFF. When all functions are OFF or more than one function is ON, the output duty cycle will be set to 100%.
- Turn off the power when changing control functions.

Control Function Selector Switch

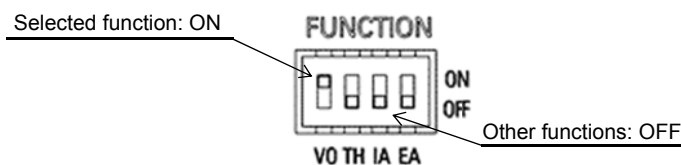

VO: Voltage control
 TH: Thermistor control
 IA: Internal adjustment control
 EA: External adjustment control

5-3. Description of Control Functions

5-3-1. Voltage Control Function

- (1) This function controls the output duty cycle by externally applying voltage from 0 to 5 V.
- (2) Set the VO control function selector switch to ON to use the voltage control function.
- (3) Do not apply more than 5.5 V to the voltage input terminals.
- (4) Do not apply control voltage when the power is off.

Connection Diagram for Voltage Control Function

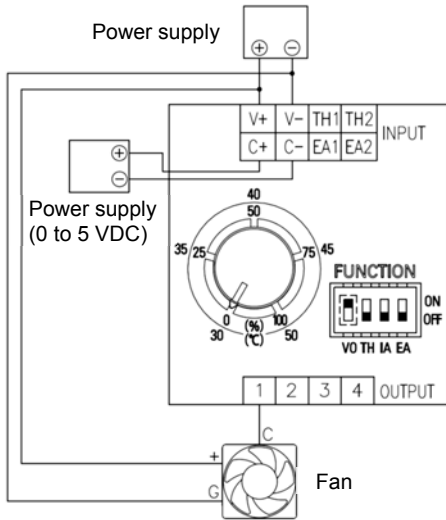

Control Voltage - Output Duty Cycle Characteristics

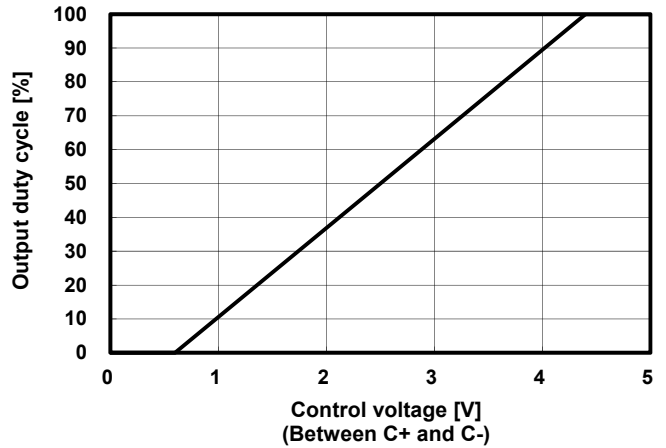

5-3-2. Thermistor Control Function

- (1) This function automatically controls the output duty cycle by using the controller's temperature set point (30 to 50°C) and an external thermistor to detect the temperature. As the temperature detected by the thermistor nears the temperature set point, the fan automatically increases, decreases, or maintains rotational speed.
- (2) Set the TH control function selector switch to ON to use the thermistor control function.
- (3) Connect a thermistor only when using the thermistor control function.
- (4) Confirm the cooling performance of the fan before connecting it.
- (5) A thermistor is not included so you will need to supply your own.
Thermistor specifications: NTC thermistor with cable, $R_{25} = 10\text{ k}\Omega$, $B_{25/85} = 3435\text{K}$

Connection Diagram for Thermistor Control Function

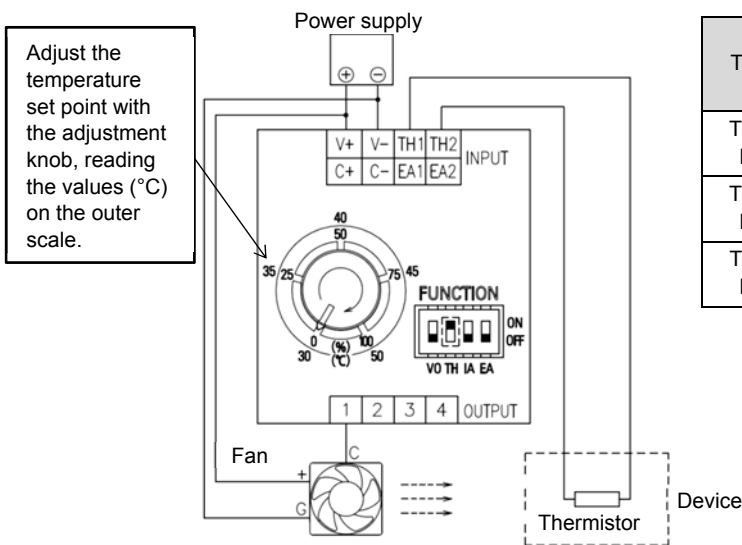

Control Conditions

Temperature conditions	Output duty cycle	Fan rotational speed (For reference)
Temperature set point < Detected temperature	Increases	Increases
Temperature set point > Detected temperature	Decreases	Decreases
Temperature set point \approx Detected temperature	Maintains	Maintains

5-3-3. Internal Adjustment Control

- (1) This function controls the output duty cycle using the adjustment knob.
- (2) Set the IA control function selector switch to ON to use the internal adjustment control function.

Connection Diagram for Internal Adjustment Control Function

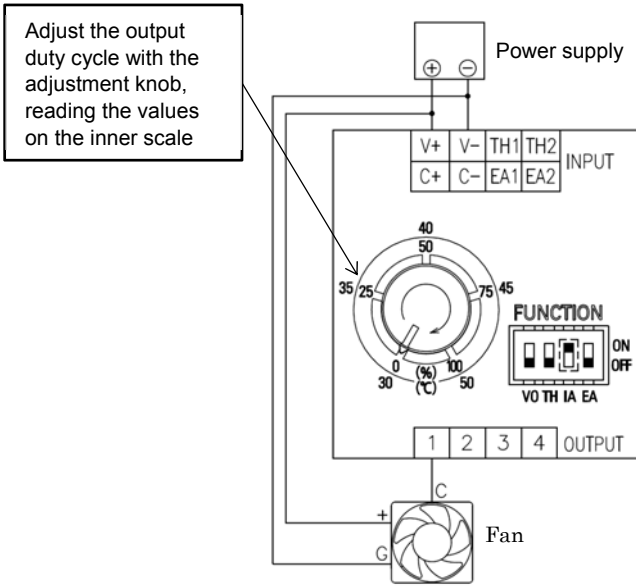

Inner Scale Reading - Output Duty Cycle Characteristics

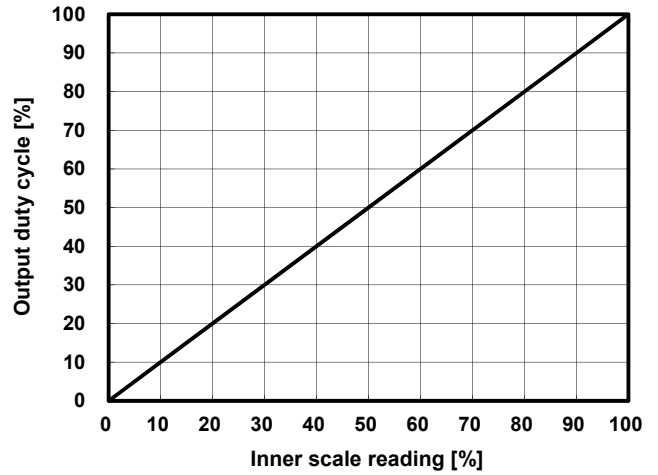

5-3-4. External Adjustment Control

- (1) This function controls the output duty cycle using a variable resistor.
- (2) Set the EA control function selector switch to ON to use the external adjustment control function.
- (3) Connect a variable resistor only when using the external adjustment control function.
- (4) A variable resistor is not included, so you will need to supply your own.
Variable resistor specifications: Total resistance = 10 kΩ, resistance taper = B

Connection Diagram for External Adjustment Control Function

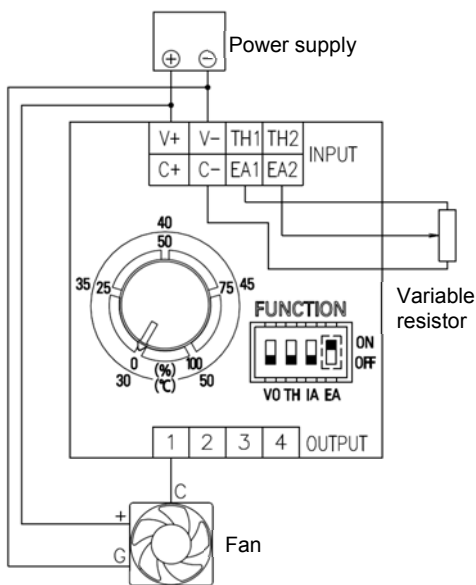

Resistance - Output Duty Cycle Characteristics

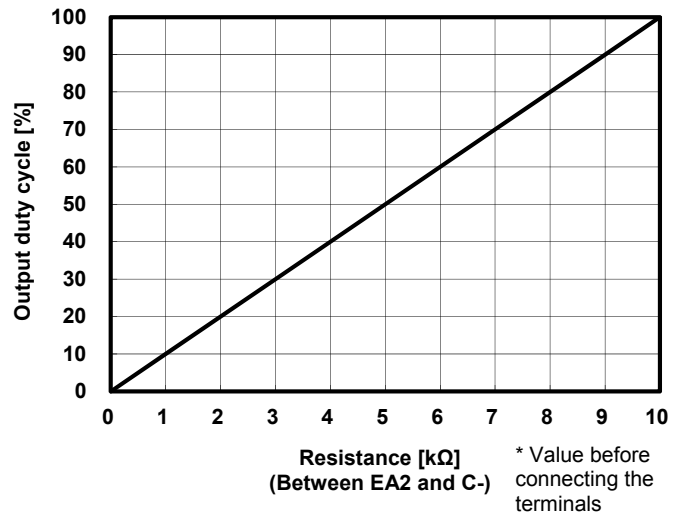

6. Dimensions

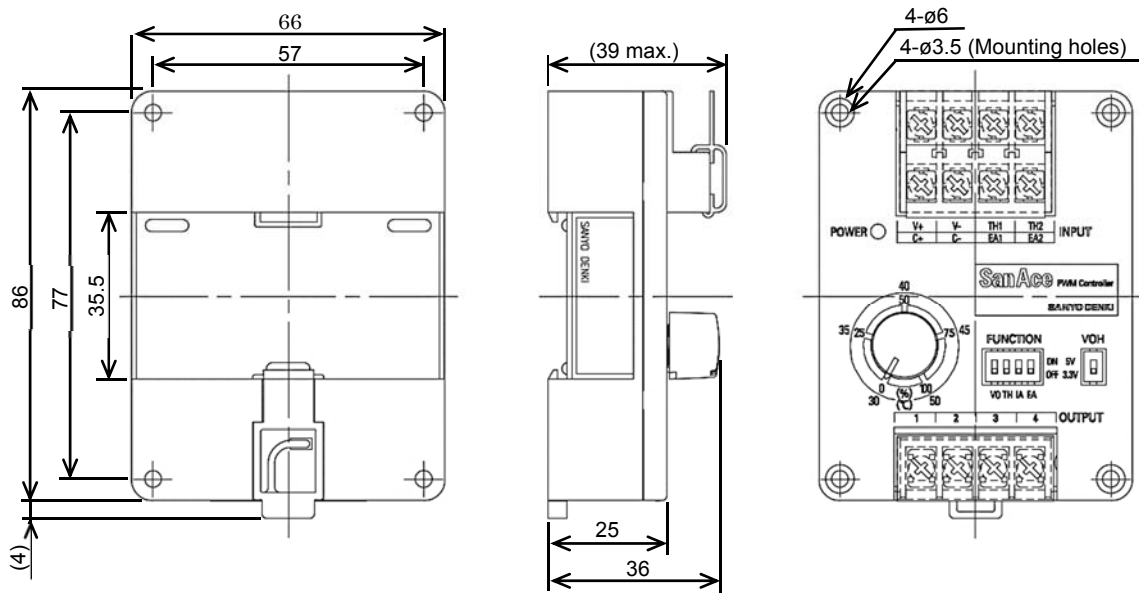

7. Specifications

Item		Specifications		Remarks
		9PC8666X-S001 *	9PC8666X-S101 *	
Rated voltage		12/24/48 VDC		
Power consumption		0.2 W		Output terminals not connected
Operating voltage range		7 to 60 VDC		
Output terminals	Number of output terminals	4		Same PWM signal sent from 4 terminals
	Input/output current	20 mA or lower		Total from 4 terminals
	Output withstand voltage	6.5 V		
PWM signal output	High-level voltage (V_{OH})	3.3 V or 5 V		Output terminals not connected
	Low-level voltage (V_{OL})	0.4 V or lower		Output terminals not connected
	PWM frequency	25 kHz		Output terminals not connected
Insulation resistance		10 MΩ or higher using a 500 VDC insulation resistance tester		Between the power supply input terminal and case
Dielectric strength		500 VAC (50/60 Hz) for 1 minute		Between power supply input terminal and case
Mass		Approx. 110 g		
Mounting		DIN rail or M3 screws		
Material		Case: Plastics		
Operating temperature range		-20 to 70°C		Non-condensing
Storage temperature range		-30 to 70°C		Non-condensing
Humidity (operating and storage)		20 to 85% RH		Non-condensing

*The other last two digits shall be applied to the customized models.

8. CE marking, Safety Standards



(1) CE marking

- This product conforms EMC directive and applies CE marking.
Applicable Standards : EN 61000-6-4、 EN 61000-6-2
- The length of cables connected to this product should be less than 3m to conform EMC directive.
- The standards are for industrial environment. It does not conform EMC directive in residential areas.

(2) Safety standards

This product is compliant with ;

cUL_{US} : UL 508、 CSA C22.2 No.14

TUV : EN 60950-1, EN62368-1

9. Product Warranty

- (1) The warranty period is one year from the date of shipment.
- (2) If the product fails within the warranty period under normal and proper use based on the contents of this instruction manual, the product will be repaired at no cost or be replaced with a new or equivalent product.
- (3) The warranty does not cover repairs in the following cases:
 - Failure or defects caused by improper handling such as dropping or applying an excessive force.
 - Failure or defects caused by disassembling, altering, or repairing the product by the user.
 - Failure or defects caused by external factors such as fires, natural disasters, pollution, salt damage, corrosive gas, and abnormal voltages.
 - Failure or defects found not to be the responsibility of SANYO DENKI.

<https://www.sanyodenki.com>

SANYO DENKI CO., LTD.

3-33-1 Minami-Otsuka, Toshima-ku, Tokyo 170-8451, Japan

Singapore Branch

988 Toa Payoh North, #04-08, Singapore 319002

Indonesia Representative Office

Summitmas II 4th Floor, Jl. Jend. Sudirman Kav.61-62, Jakarta 12190, Indonesia

SANYO DENKI EUROPE SA.

P.A. PARIS NORD II , 48 Allée des Erables-VILLEPINTE, BP.57286, F-95958 ROISSY CDG CEDEX, France

Poland Branch

ul. Wodociągowa 56 30-205 Kraków, Polska

SANYO DENKI AMERICA, INC.

468 Amapola Avenue Torrance, CA 90501, U.S.A.

SANYO DENKI SHANGHAI CO., LTD.

Room 2106-2110, Bldg A, Far East International Plaza, No.319, Xianxia Road, Shanghai, 200051, China

SANYO DENKI (H.K.) CO., LIMITED

Room 2305, 23/F, South Tower, Concordia Plaza, 1 Science Museum Road, TST East, Kowloon, Hong Kong

SANYO DENKI TAIWAN CO., LTD.

N-711, 7F, Chia Hsin 2nd Bldg., No.96, Sec.2, Zhongshan N. Rd., Taipei 10449, Taiwan

SANYO DENKI GERMANY GmbH

Frankfurter Strasse 80-82, 65760 Eschborn, Germany

SANYO DENKI KOREA CO., LTD.

15F, KDB Building, 372, Hangang-daero, Yongsan-gu, Seoul, 04323, Korea

Busan Branch

8F, CJ Korea Express Building, 119, Daegyo-ro, Jung-gu, Busan, 48943, Korea

SANYO DENKI (Shenzhen) CO., LTD.

02-11 2/F, Shenzhen International Chamber of Commerce Tower, No.168 Fuhua 3 Road, Futian District, Shenzhen, 518048, Guangdong, China

SANYO DENKI (THAILAND) CO., LTD.

388 Exchange Tower, 25th Floor, Unit 2501-1, Sukhumvit Road, Klongtoey, Klongtoey, Bangkok 10110 Thailand

SANYO DENKI INDIA PRIVATE LIMITED

#14 (Old No.6/3), Avenue Road, Nungambakkam, Chennai - 600034, Tamil Nadu, India

SANYO DENKI (Tianjin) CO., LTD.

Room AB 16th Floor TEDA Building, No. 256 Jie Fang Nan Road, Hexi District, Tianjin 300042 China

TEL: +81 3 5927 1020

TEL: +65 6223 1071

TEL: + 62 21 252 3202

TEL: +33 1 48 63 26 61

TEL: +48 12 427 30 73

TEL: +1 310 783 5400

TEL: +86 21 6235 1107

TEL: +852 2312 6250

TEL: +886 2 2511 3938

TEL: +49 6196 76113 0

TEL: +82 2 773 5623

TEL: +82 51 796 5151

TEL: +86 755 3337 3868

TEL: +66 2261 8670

TEL: +91 44 420 384 72

TEL: +86 22 2320 1186

The names of companies and/or their products specified in this manual are the trade names, and/or trademarks and/or registered trademarks of such respective companies.

*Specifications are subject to change without notice.

Translated version of the original instructions